

REV	DESCRIPTION OF CHANGE	REVIEWED BY	ISSUE DATE
A	FIRST ISSUE	LEO	2021-10-11

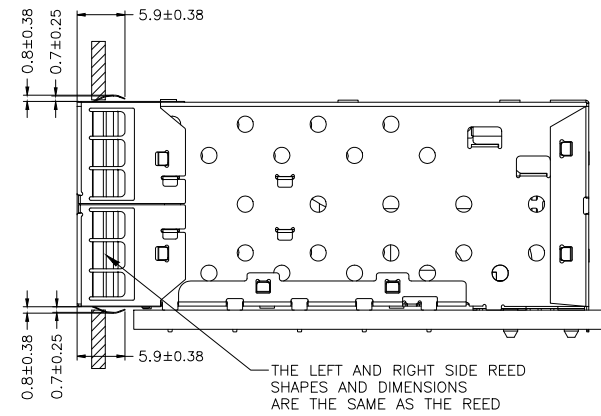

NOTES:
 MATERIAL:
 CAGE: COPPER ALLOY 30u" MIN NI-PLATED, THICKNESS 0.25 MM
 CONNECTOR:
 PLASTIC HOUSING: HIGH TEMPERATURE LCP, UL94 V-0.
 SPRING: STAINLESS STEEL
 CONTACTS: PHOSPHOR BRONZE
 CONTACT PLATING: 15u" MIN. GOLD ON MATING AREA,
 150u" MATTE TIN ON SOLDER TAILS
 PACKAGING: TRAY PACKAGING.
 OPERATING TEMPERATURE: -40°C TO +85°C
 STORAGE TEMPERATURE: -55°C TO +105°C

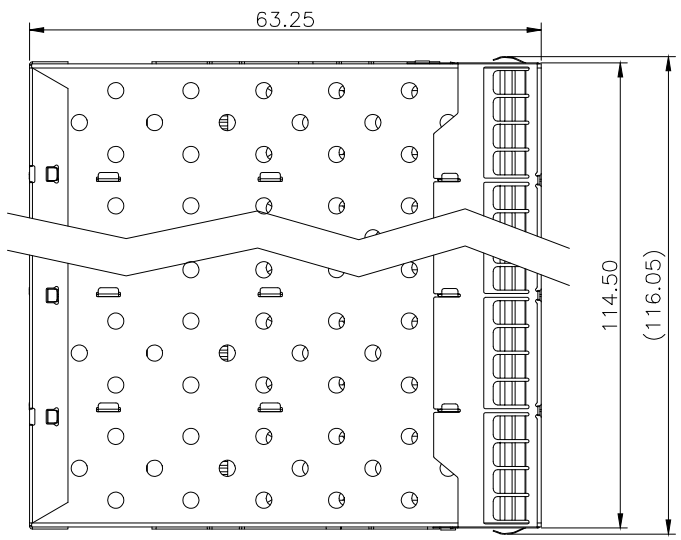
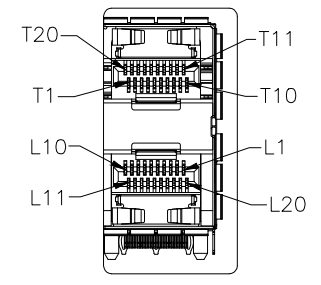
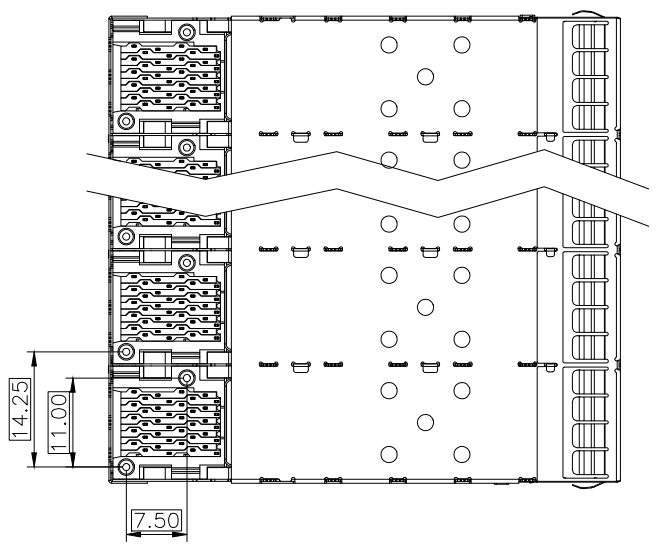
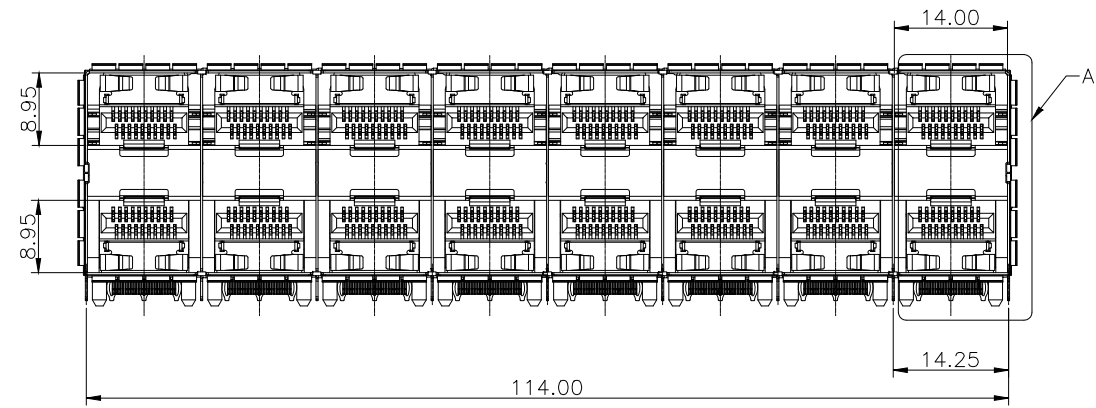
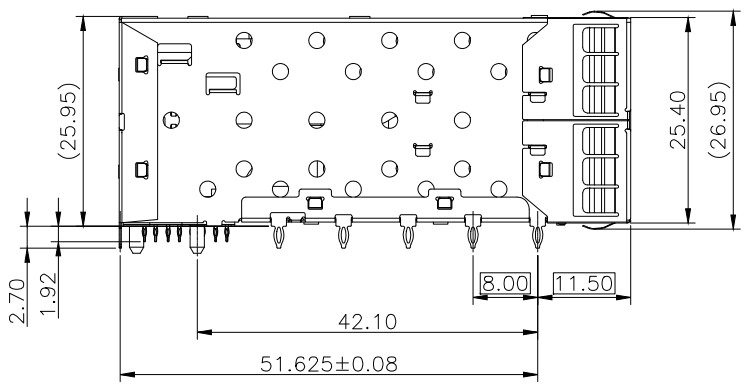

DETAIL A
1:1

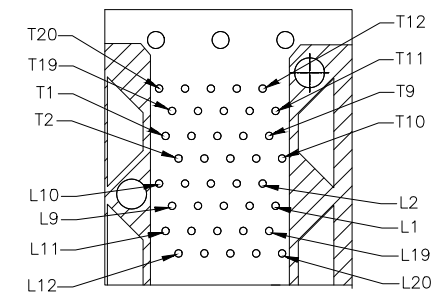

CONNECTOR PIN-OUT
COMPONENT SIDE OF BOARD



TITLE SFP+ 2X8 CAGE & CONNECTOR WITH EMI SPRING FINHER			LINK-PP INT'L TECHNOLOGY CO., LIMITED			
PART NO. LP28BC01001			GENERAL TOLERANCE		UNIT:MM	SIZE:A4
APPROVE	CHECK	DRAW	• X±0.20	• X±1°	SCALE:1:1	SHEET:1/4
LEO	JAMES	JAMES	• XX±0.15	• XX±5°		
			• XXX±0.10			
					REVISION	REV:A

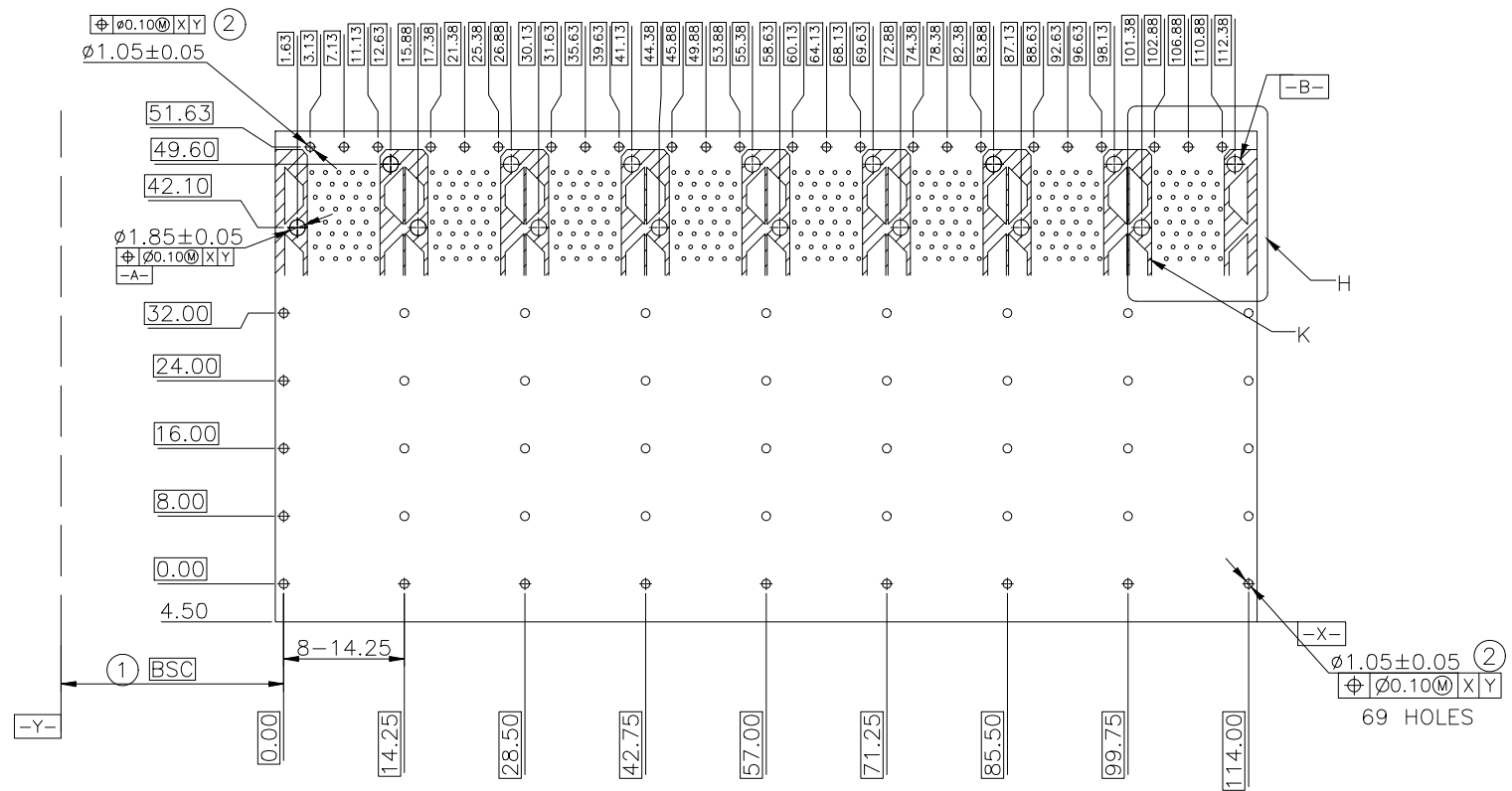

RECOMMENDED PCB CONFIGURATION

NOTES:

- ① DATUM AND BASIC DIMENSIONS ESTABLISHED BY CUSTOMER.
- ② 1.05 mm DIAMETER HOLES ARE CHASSIS GROUND.

THE ENTIRE AREA OF THE CONNECTOR FOOTPRINT TO BE CONSIDERED THE KEEP OUT AREA FOR COMPONENTS (OTHER THAN LIGHT PIPE LED'S) THIS AREA IS INDICATED BY THE DASHED LINE

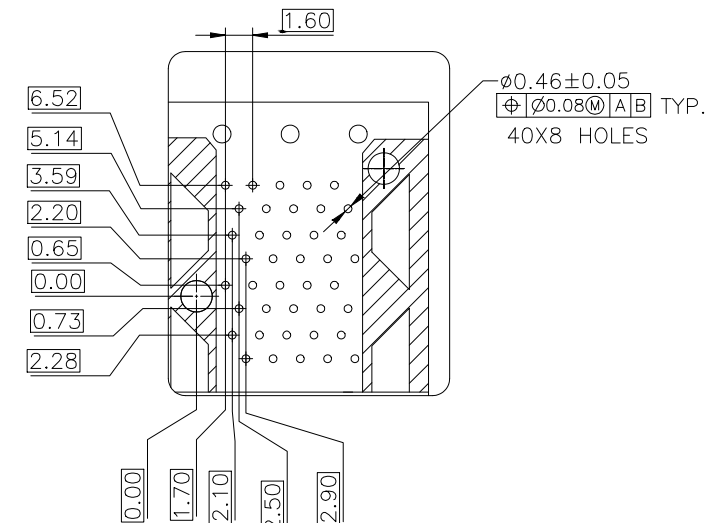

DETAIL H
2:1

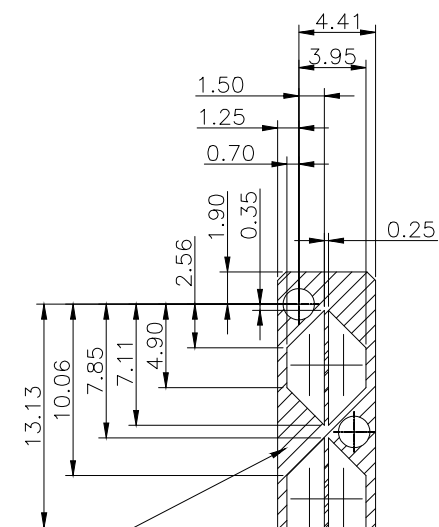

DETAIL LIGHT PIPE LOCATION AND OTHER ZONES
DETAIL K
2:1



TITLE SFP+ 2X8 CAGE &CONNECTOR WITH EMI SPRING FINHER			LINK-PP INT'L TECHNOLOGY CO., LIMITED		
PART NO. LP28BC01001			GENNERAL TOLERANCE	UNIT:MM	SIZE:A4
APPROVE	CHECK	DRAW	 SCALE:1:1	SHEET:2/4	REV:A
LEO	JAMES	JAMES			

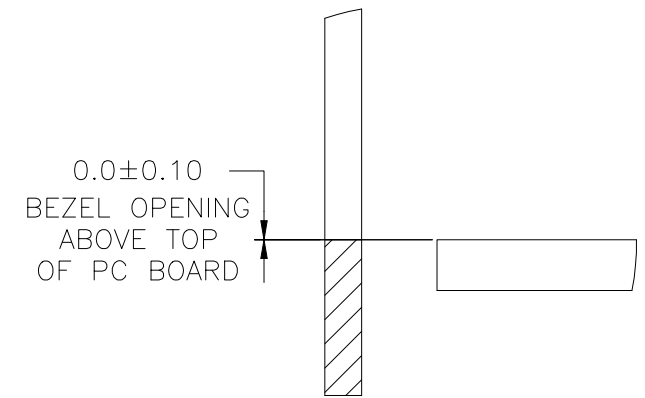
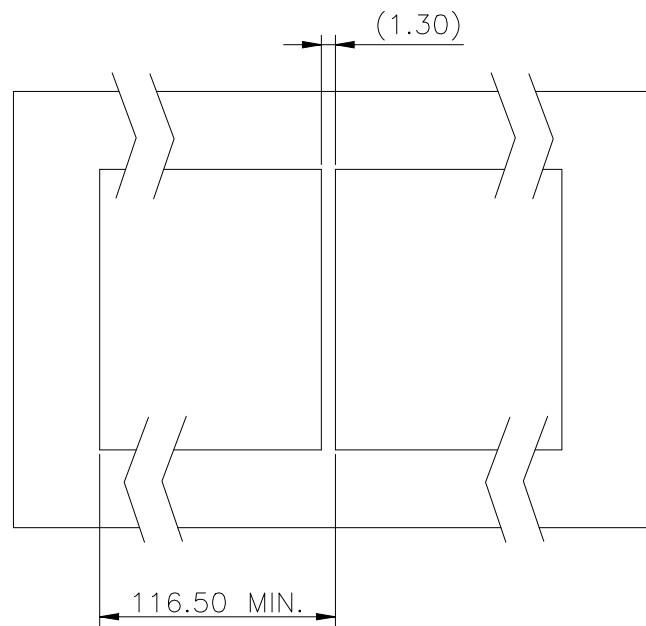
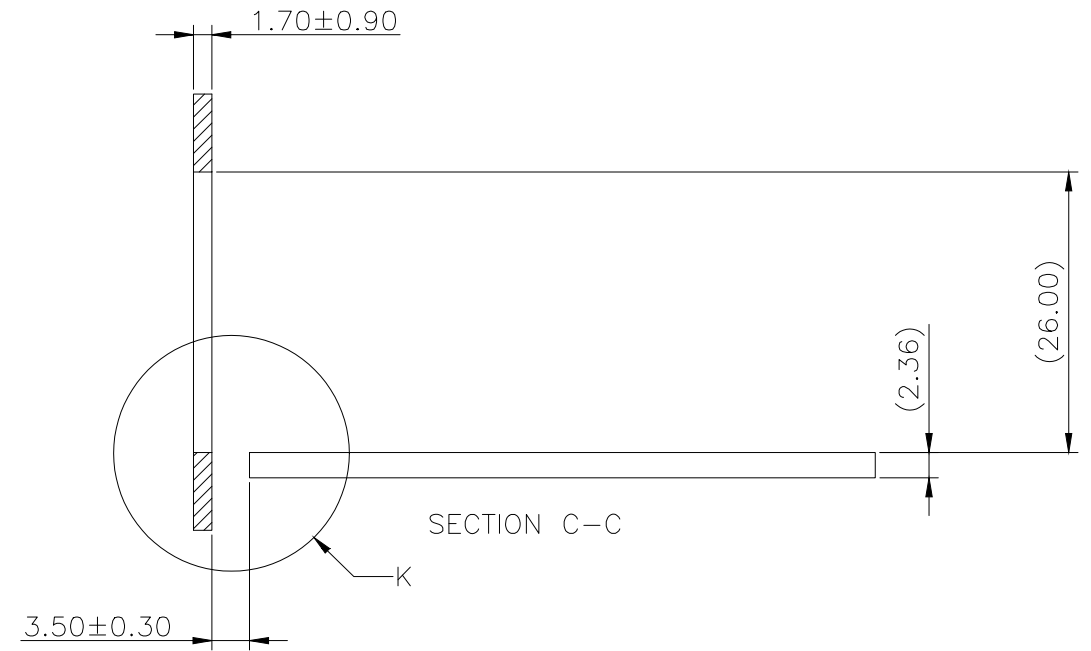
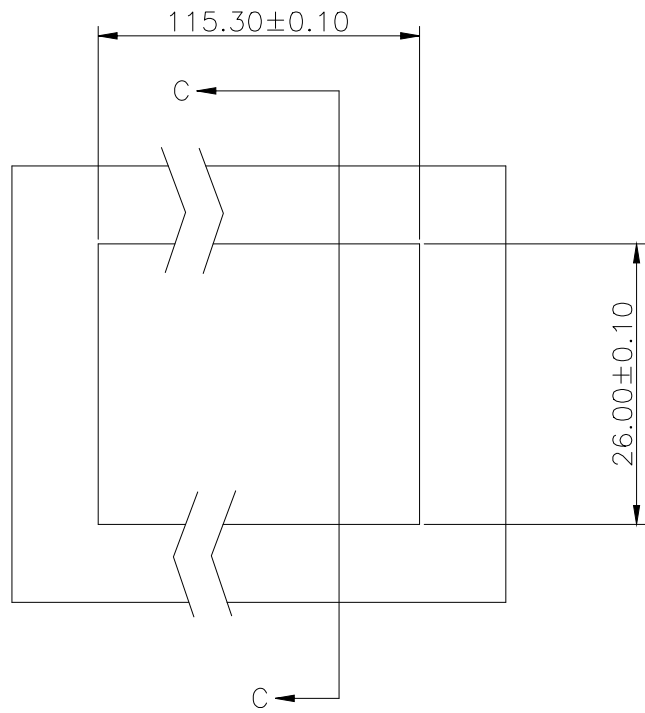

RECOMMENDED BEZEL DESIGN

DETAIL K
2:1



TITLE SFP+ 2X8 CAGE &CONNECTOR WITH EMI SPRING FINHER			LINK-PP INT'L TECHNOLOGY CO., LIMITED			
PART NO. LP28BC01001			GENNERAL TOLERANCE		UNIT:MM	SIZE:A4
APPROVE	CHECK	DRAW	° X±0.20	° X±1°	SCALE:1:1	SHEET:3/4
LEO	JAMES	JAMES	° XX±0.15	° XX±5°		
			° XXX±0.10			
						REV:A

PACKAGE INFORMATION AND LABEL

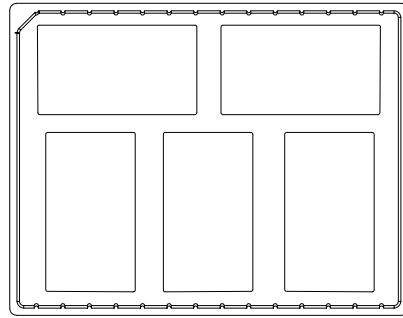

1. 5PCS PRODUCTS IN TRAYS

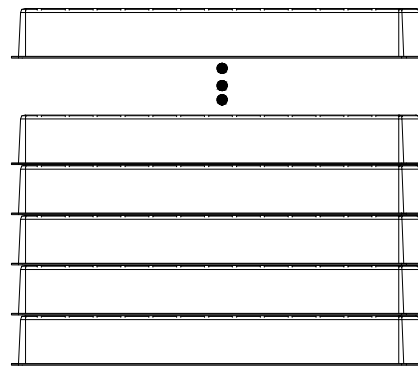

2. 4PCS TRAYS OVERLAY:
(THE NEXT TRAY NEED ROTATE 180 DEGREE AND PUT IT ON PREVIOUS TRAY.)

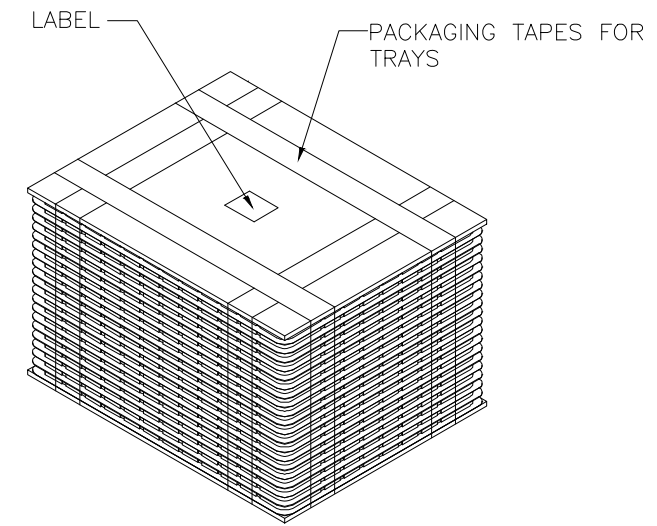

3. LABEL & PACKAGING TAPES FOR TRAYS:

PACKAGING LISTS	
ITEM	Q'TY
PRODUCT	20 PCS
TRAY	4 PCS
BOX(L340*W265*H200MM)	1 PCS
LABLE	2 PCS
PACKAGING TAPES	8 M (ABOUT)

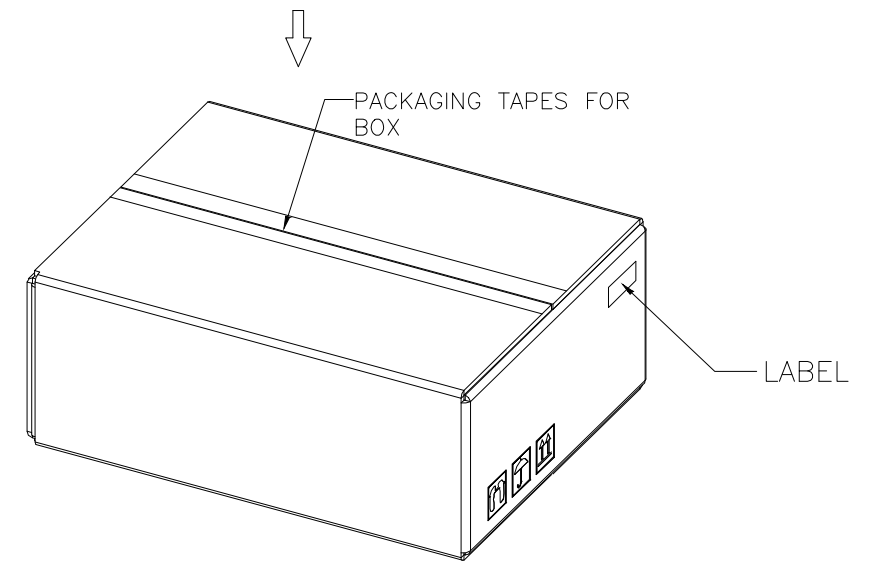

4. LABEL & PACKAGING TAPES FOR BOX



TITLE SFP+ 2X8 CAGE &CONNECTOR WITH EMI SPRING FINHER			LINK-PP INT'L TECHNOLOGY CO., LIMITED			
PART NO. LP28BC01001			GENNERAL TOLERANCE		UNIT:MM	SIZE:A4
APPROVE	CHECK	DRAW	◦ X±0.20	◦ X±1°	SCALE:1:1	SHEET:4/4
LEO	JAMES	JAMES	◦ XX±0.15	◦ XX±5°		
			◦ XXX±0.10			
						REV:A