

REV	DESCRIPTION OF CHANGE	REVIEWED BY	ISSUE DATE
B	FIRST ISSUE	LEO	2021-09-03

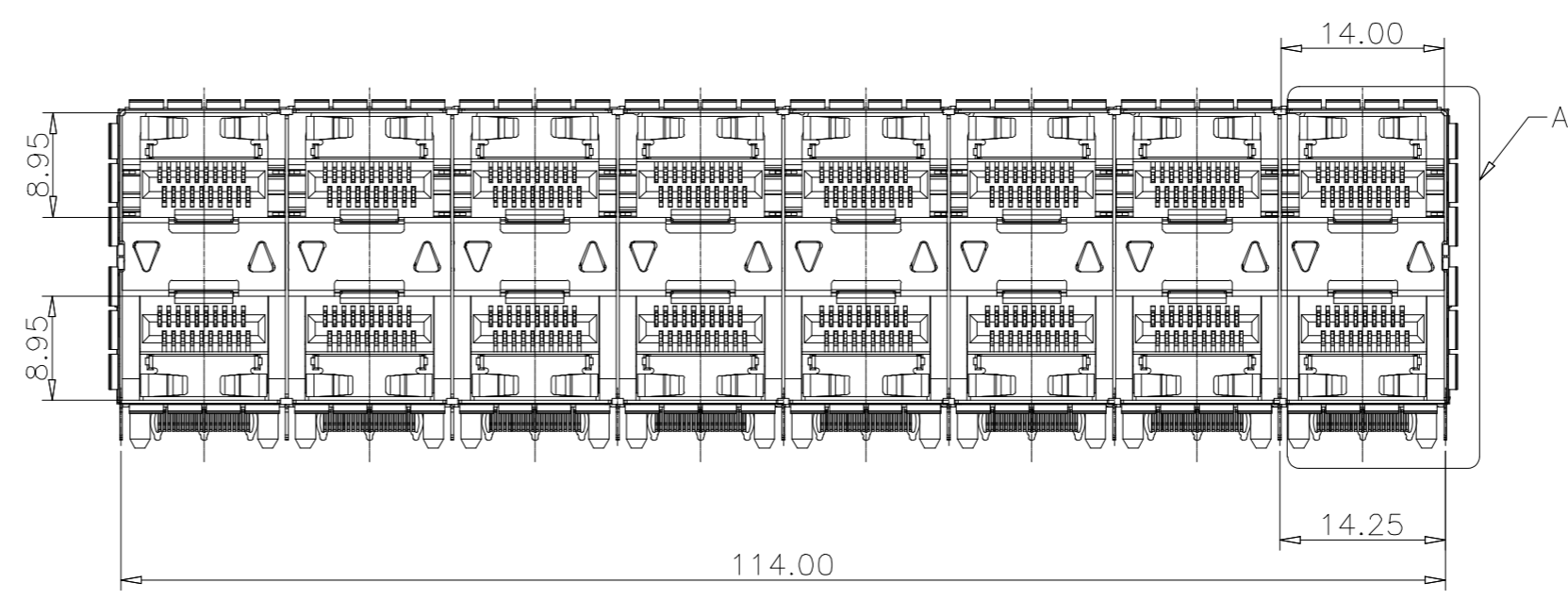

NOTES:
 MATERIAL:
 CAGE: COPPER ALLOY NI-PLATED, THICKNESS 0.25 MM
 CONNECTOR:
 PLASTIC HOUSING: HIGH TEMPERATURE LCP, UL94 V-0.
 LIGHT PIPE: POLYCARBONATE; COLOR: CLEAR
 SPRING: STAINLESS STEEL
 CONTACTS: PHOSPHOR BRONZE
 CONTACT PLATING: 15u" MIN. GOLD ON MATING AREA,
 150u" MATTE TIN ON SOLDER TAILS
 PACKAGING: TRAY PACKAGING.
 OPERATING TEMPERATURE: -40°C TO +85°C
 STORAGE TEMPERATURE: -55°C TO +105°C

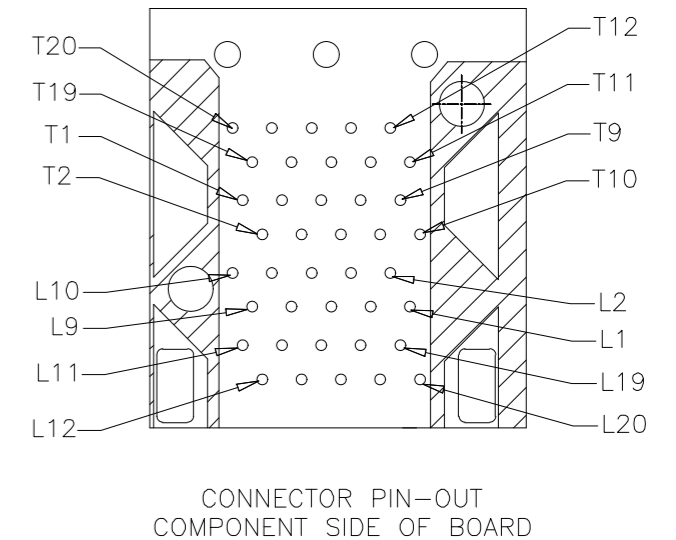
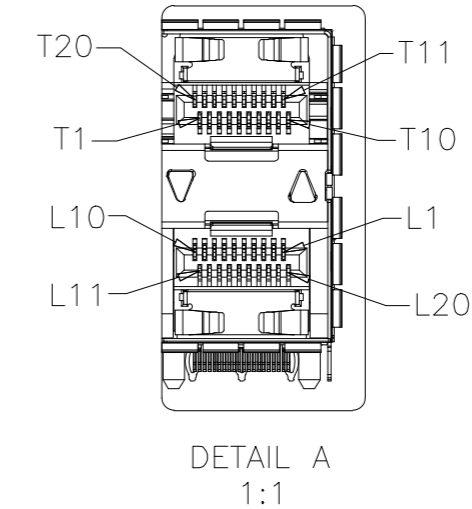
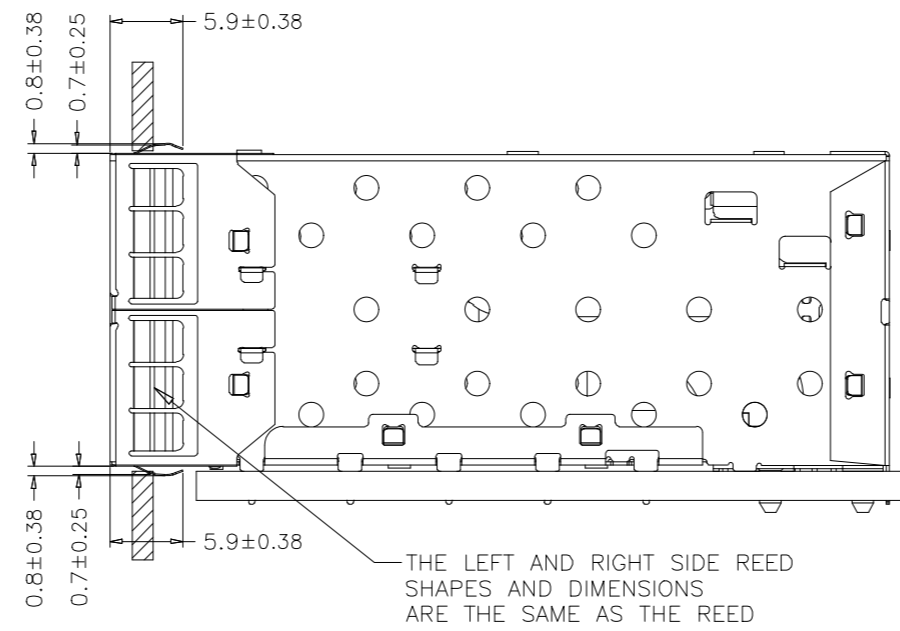

TITLE SFP+ 2X8 CAGE & CONNECTOR WITH EMI SPRING FINGER LIGHT PIPE			LINK-PP INT'L TECHNOLOGY CO., LIMITED			
PART NO. LP28BC01301			GENERAL TOLERANCE		UNIT:MM	SIZE:A4
APPROVE	CHECK	DRAW	° X±0.20	° X±1°	SCALE:1:1	SHEET:1/4
LEO	JAMES	JAMES	° XX±0.15	° XX±5°		
			° XXX±0.10			

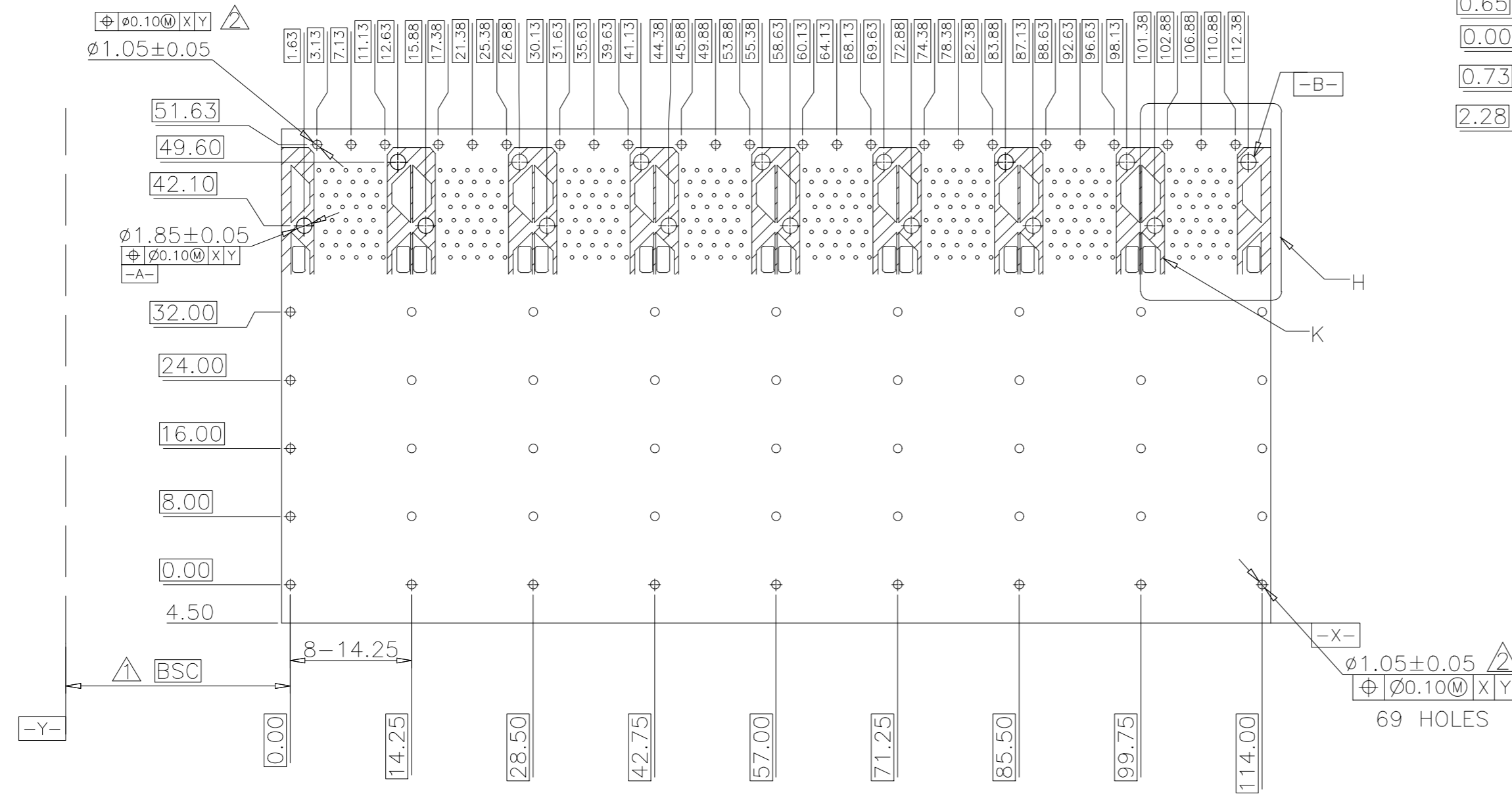

RECOMMENDED PCB CONFIGURATION

- NOTES:
1. DATUM AND BASIC DIMENSIONS ESTABLISHED BY CUSTOMER.
 2. 1.05 mm DIAMETER HOLES ARE CHASSIS GROUND.

THE ENTIRE AREA OF THE CONNECTOR FOOTPRINT TO BE CONSIDERED THE KEEP OUT AREA FOR COMPONENTS (OTHER THAN LIGHT PIPE LE'S) THIS AREA IS INDICATED BY THE DASHED LINE

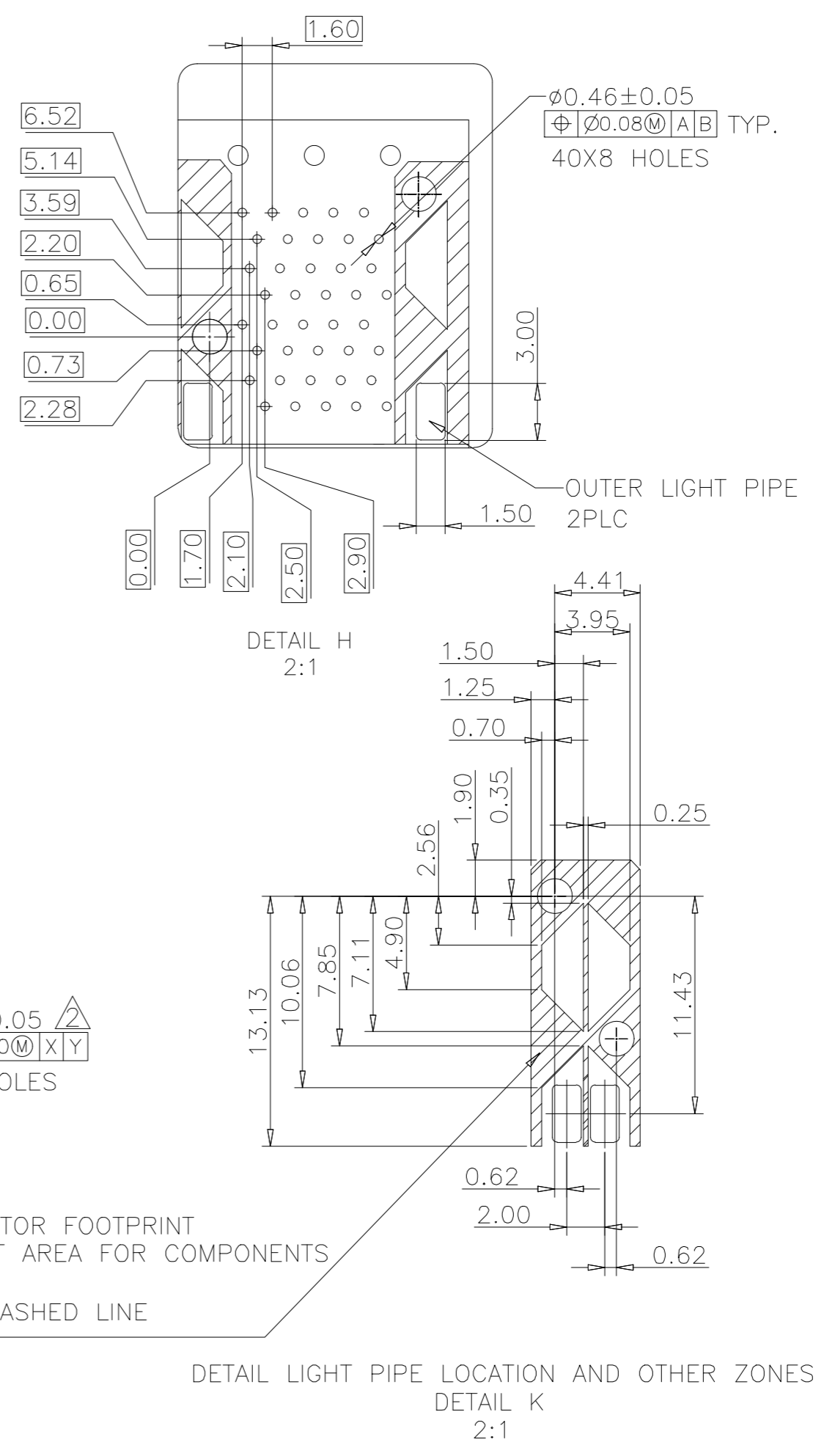

DETAIL LIGHT PIPE LOCATION AND OTHER ZONES
DETAIL K
2:1



TITLE SFP+ 2X8 CAGE & CONNECTOR WITH EMI SPRING FINGER LIGHT PIPE			LINK-PP INT'L TECHNOLOGY CO., LIMITED		
PART NO. LP28BC01301			GENERAL TOLERANCE		UNIT:MM SIZE:A4
APPROVE LEO	CHECK JAMES	DRAW JAMES	$X \pm 0.20$ $XX \pm 0.15$ $XXX \pm 0.10$	$X \pm 1^\circ$ $XX \pm 5^\circ$	SCALE:1:1 SHEET:2/4 REV:B

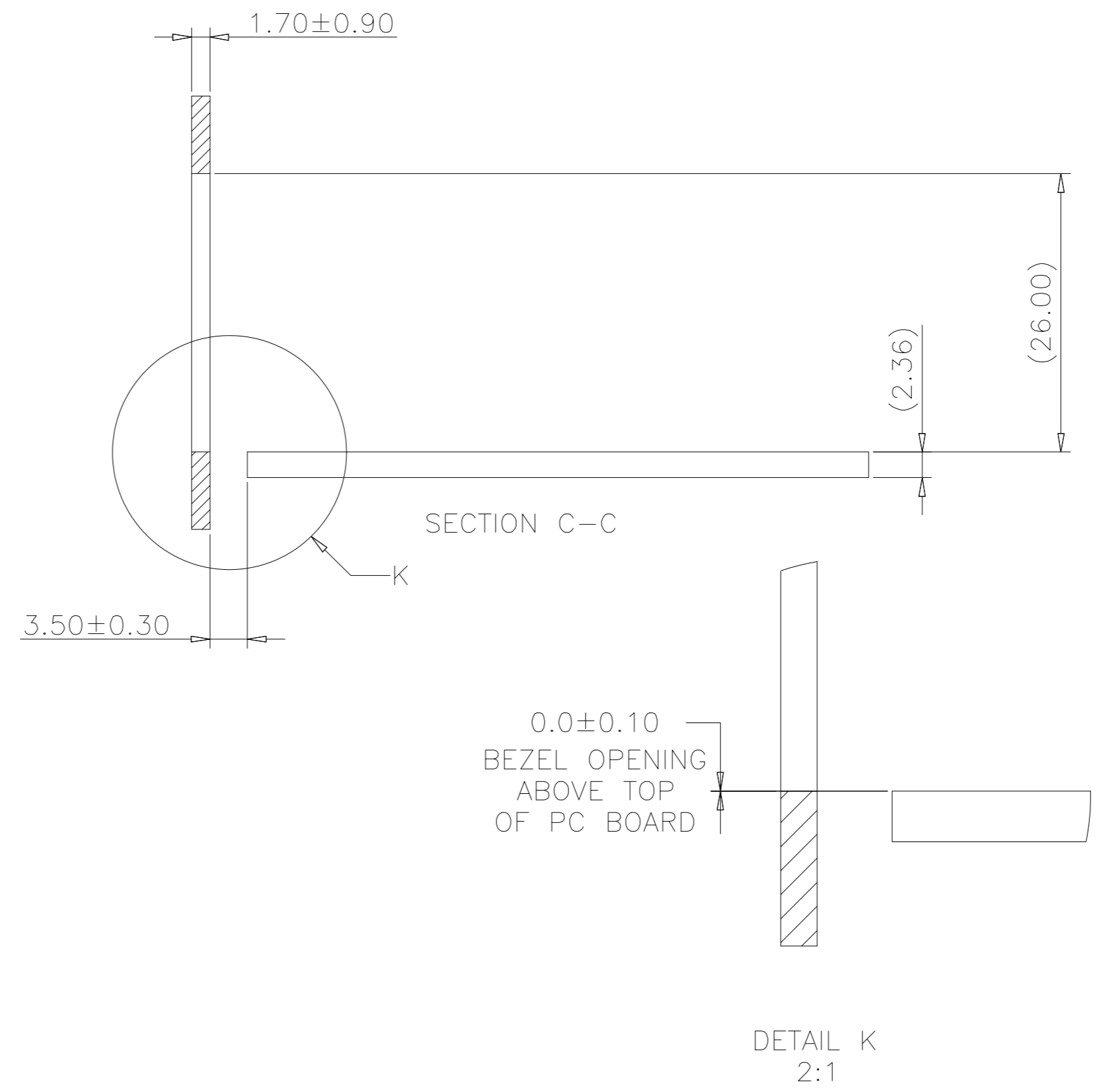
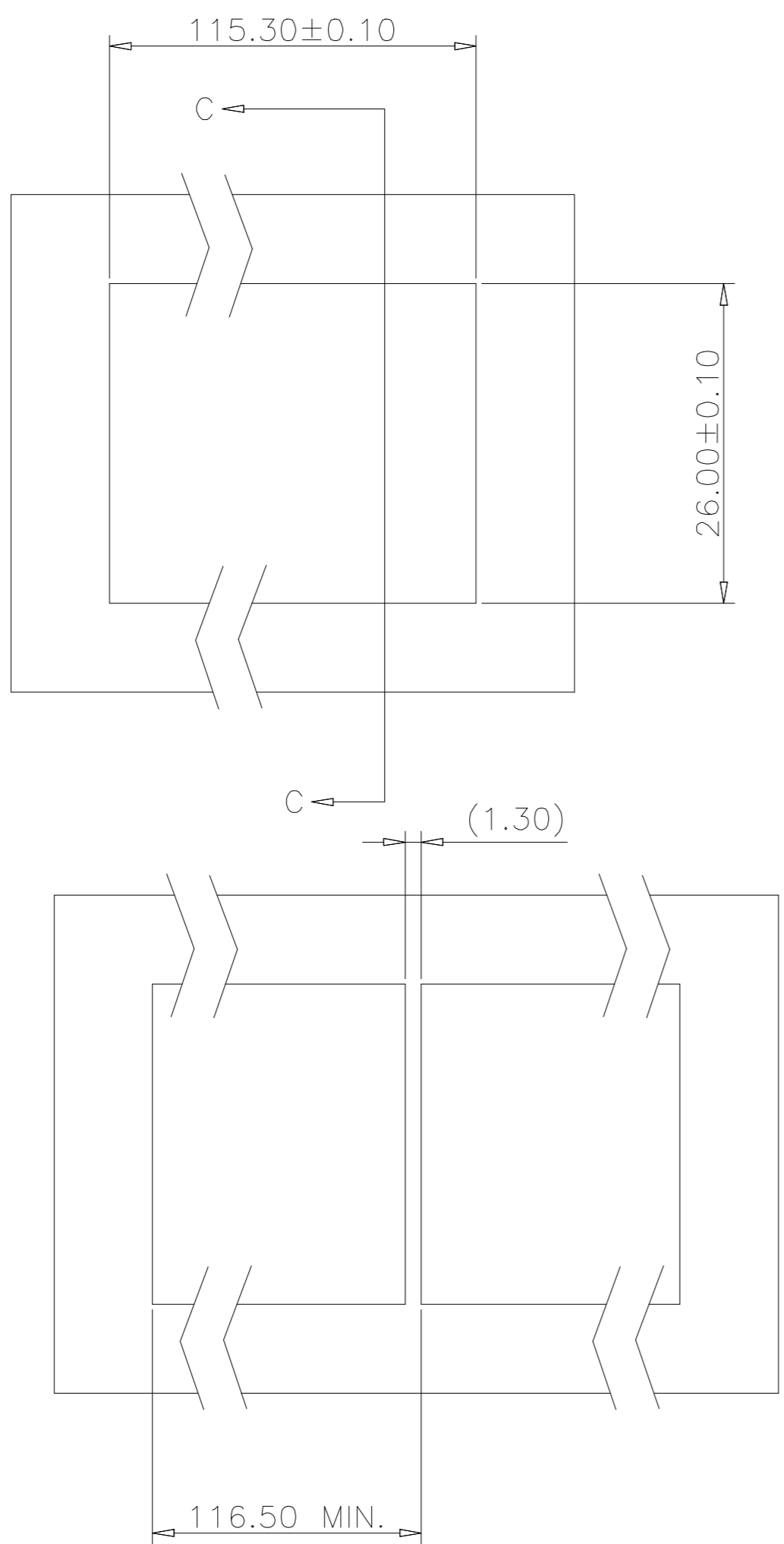

RECOMMENDED BEZEL DESIGN



TITLE SFP+ 2X8 CAGE & CONNECTOR WITH EMI SPRING FINGER LIGHT PIPE			LINK-PP INT'L TECHNOLOGY CO., LIMITED			
PART NO. LP28BC01301			GENNERAL TOLERANCE		UNIT:MM	SIZE:A4
APPROVE	CHECK	DRAW	° X±0.20	° X±1°	SCALE:1:1	SHEET:3/4
LEO	JAMES	JAMES	° XX±0.15	° XX±5°		
			° XXX±0.10			

PACKAGE INFORMATION AND LABEL

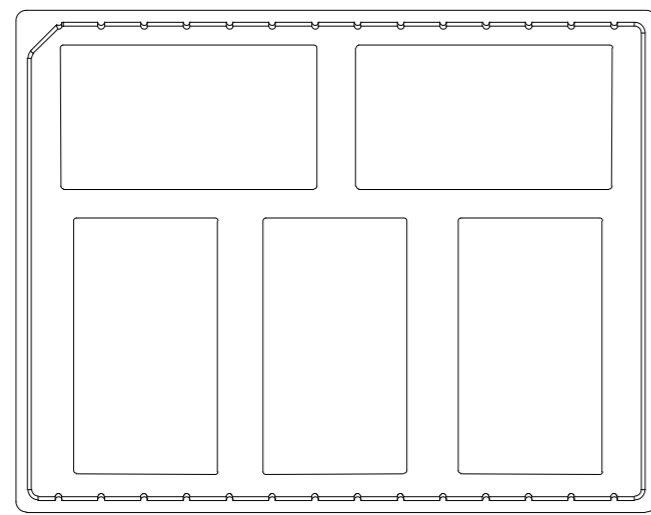

1. 5PCS PRODUCTS IN TRAYS

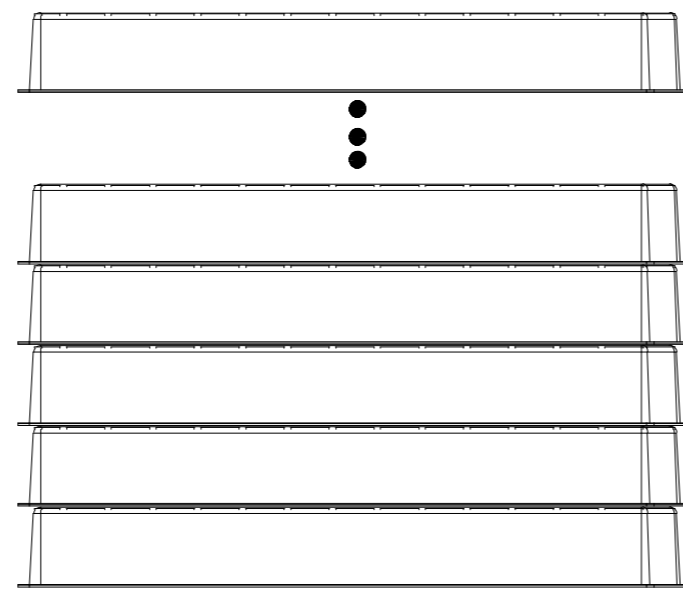
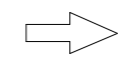

2. 4PCS TRAYS OVERLAY:
(THE NEXT TRAY NEED ROTATE 180 DEGREE AND PUT IT ON PREVIOUS TRAY.)

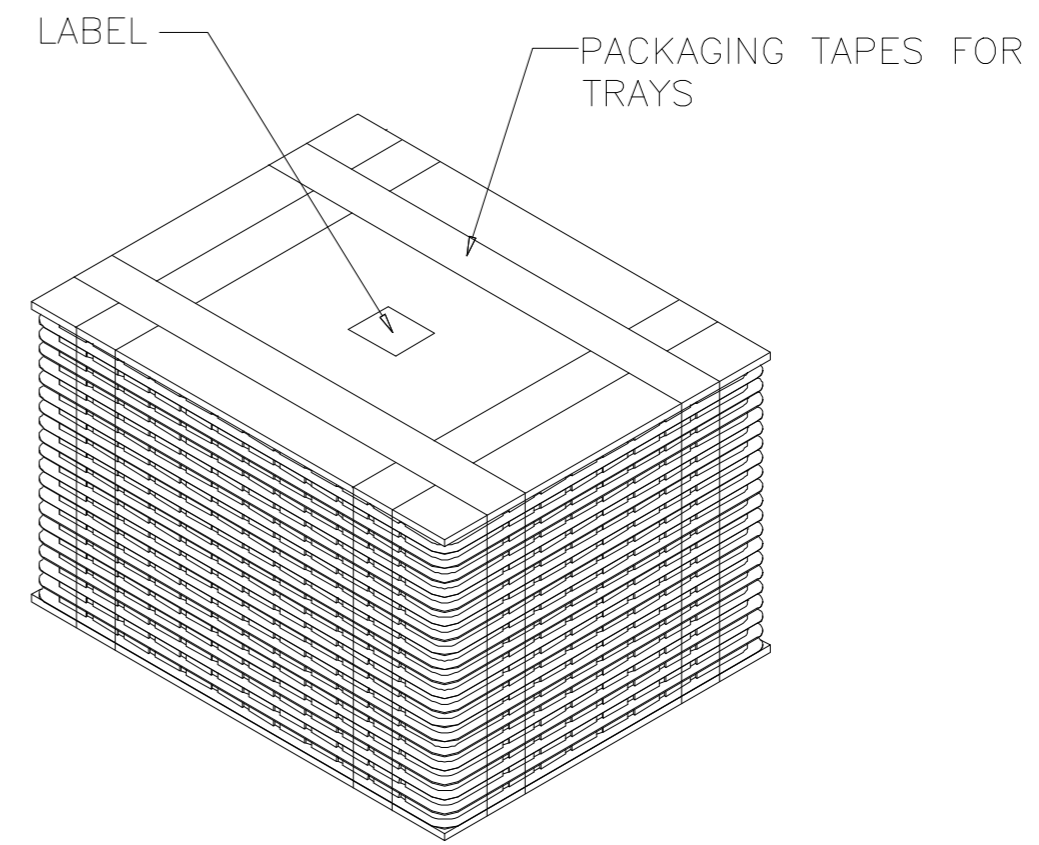
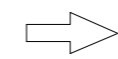

3. LABEL & PACKAGING TAPES FOR TRAYS:

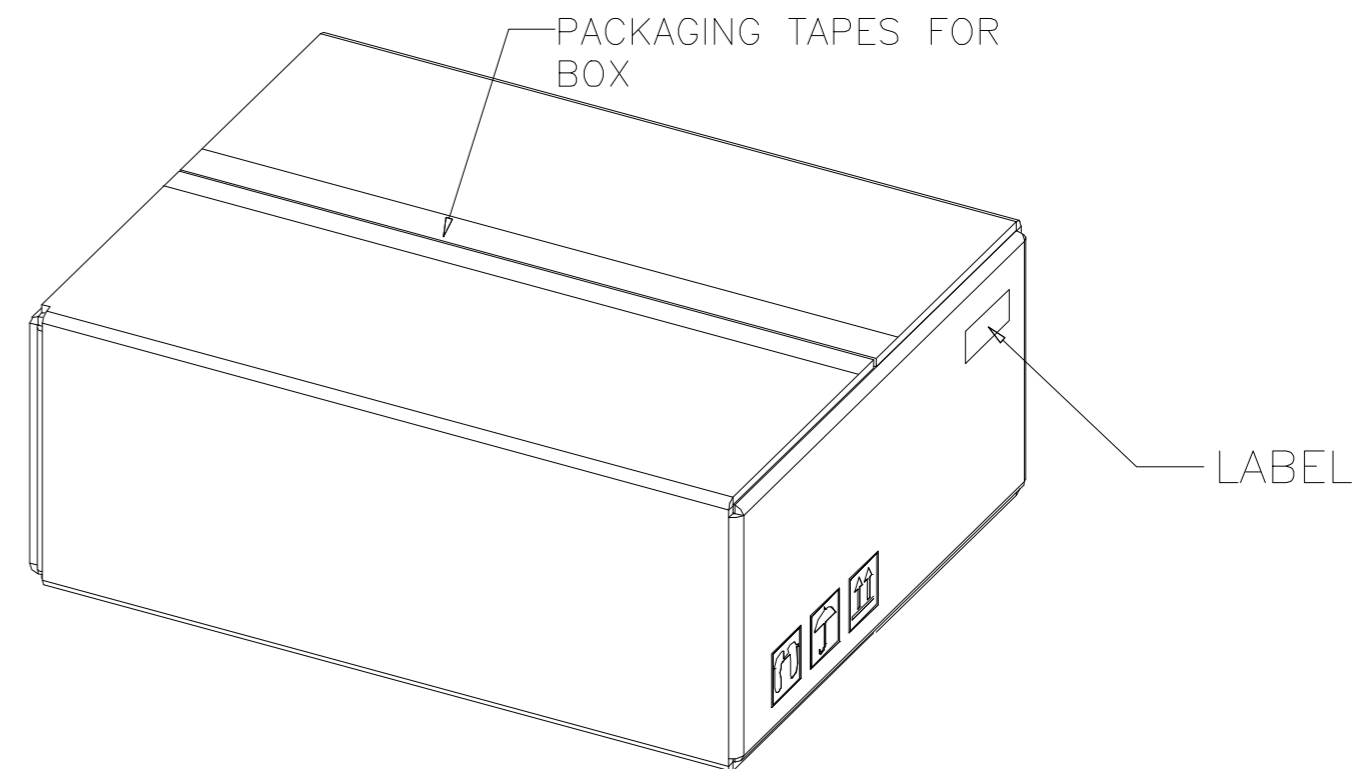
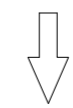

4. LABEL & PACKAGING TAPES FOR BOX

PACKAGING LISTS	
ITEM	Q'TY
PRODUCT	20 PCS
TRAY	4 PCS
BOX(L340*W265*H200MM)	1 PCS
LABLE	2 PCS
PACKAGING TAPES	8 M (ABOUT)



TITLE SFP+ 2X8 CAGE & CONNECTOR WITH EMI SPRING FINGER LIGHT PIPE			LINK-PP INT'L TECHNOLOGY CO., LIMITED				
PART NO. LP28BC01301			GENNERAL TOLERANCE			UNIT:MM	SIZE:A4
APPROVE	CHECK	DRAW	◦ X±0.20	◦ X±1°	SCALE:1:1	SHEET:4/4	REV:B
LEO	JAMES	JAMES	◦ XX±0.15	◦ XX±5°			
			◦ XXX±0.10				