

LQD-CW400-DR4C

400G QSFP-DD DR4 Transceiver

Product Features

- Compliant with IEEE Std 802.3bs
- Compliant with 400G-DR4 optical specifications
- Compliant with QSFP-DD MSA
- Compliant with CMIS4.0 Management interface specifications
- 8x53.125Gb/s electrical interface (400GAUI-8)
- Up to 0.5km transmission on single mode fiber (SMF) with FEC
- Single +3.3V power supply
- Case temperature range: 0 ~ +70°C
- Maximum power consumption 9.5W
- RoHS complaint

Applications

- 400G Ethernet
- Data Center Interconnect
- Infiniband Interconnect
- Enterprise Networking

Standards

- IEEE 802.3cd
- QSFP-DD MSA
- CMIS4.0

Descriptions

LQD-CW400-DR4C is a transceiver module designed for 500m optical communication applications, and it is compliant to 100G Lambda MSA standard. This module can convert 8-channel 53.125Gb/s electrical data to 4-channel 106.25Gb/s optical signals, and multiplex them into a single channel for 425Gb/s optical transmission. Similarly, it optically de-multiplexes a 425Gb/s input into 4-channel signals, and converts them to 8-channel output electrical data on the receiver side. It has been designed to meet the harshest external operating conditions including temperature, humidity and EMI interference. The module offers very high functionality and feature

integration, accessible via a two-wire serial interface.

Absolute Maximum Ratings

It has to be noted that the operation in excess of any individual absolute maximum ratings might cause permanent damage to this module.

Parameter	Symbol	Min	Max	Units
Storage Temperature Range	TSTG	-40	+85	°C
Supply Voltage	VCC	0	4	V
Relative Humidity	RH	10% to 90% non-condensing		

Recommended Operating Conditions

Electrical and optical characteristics below are defined under this operating environment, unless otherwise specified.

Parameter	Symbol	Min	Max	Units
Case Temperature- Operating	T _{CASE}	0	70	°C
Supply Voltage	V _{CC}	3.14	3.46	V
Pre-FEC Bit Error Ratio			2.4x10 ⁻⁴	
Post-FEC Bit Error Ratio			1x10 ⁻¹²	
Link Distance		2	500	M
Instantaneous peak current at hot plug	ICC_IP		4000	mA
Sustained peak current at hot plug	ICC_SP		3300	mA
Power Consumption	PDISS		10	W
Maximum Power Dissipation, Low Power Mode	PDLP		1.5	W

Transmitter Optical Specifications

Transmitter Parameter	Symbol	Min	Typical	Max	Units
Lane Wavelength Range	λ _{C0}	1264.5	1271	1277.5	nm
	λ _{C1}	1284.5	1291	1297.5	nm
	λ _{C2}	1304.5	1311	1317.5	nm
	λ _{C3}	1324.5	1331	1337.5	nm
Modulation Format		PAM4			
Average Optical Power per lane	AOPL	-3.2		4.4	dBm

Outer Optical Modulation Amplitude (OMA _{outer}), each lane	TOMA			3.7	dBm
Outer Optical Modulation Amplitude (OMA _{outer}) each lane: for TDECQ <1.4dB for 1.4 ≤ TDECQ ≤ 3.4dB	TOMA	-0.2 -1.6+TDECQ			
Difference in launch power between any two lanes (OMA _{outer})	DP			3.9	dB
Transmitter and Dispersion Eye Closure for PAM4 (TDECQ), each lane	TDECQ			3.4	dB
Transmitter eye closure for PAM4(TECQ)	TECQ			3.4	dB
TDECQ - TECQ				2.5	dB
Over/under-shoot				22	%
Transmitter power excursion				1.8	dBm
Average Launch Power of OFF Transmitter, each lane	TOFF			-16	dBm
Extinction Ratio, each lane	ER	3.5			dB
Transmitter transition time				17	ps
Optical Return Loss Tolerance	ORL			17.1	dB
Transmitter Reflectance	TR			-26	dB

Receiver Parameter		Min	Typical	Max	Units
Line wavelengths	λ_{C0}	1264.5	1271	1277.5	nm
	λ_{C1}	1284.5	1291	1297.5	nm
	λ_{C2}	1304.5	1311	1317.5	nm
	λ_{C3}	1324.5	1331	1337.5	nm
Damage Threshold, each lane	AOPD	5.4			dBm
Average Receive Power, each lane	AOPR	-7.2		4.4	dBm
Receive Power (OMA _{outer}), each lane	OMAR			3.7	dBm
Difference in receive power between any two lanes (OMA _{outer})	DR			4.1	dB
Receiver Reflectance	RR			-26	dB
Receiver Sensitivity (OMA _{outer}), each lane for TECQ <1.4dB for 1.4 ≤ TECQ ≤ 3.4dB	SOMA			-4.6 -6+TECQ	dBm
Stressed Receiver Sensitivity (OMA _{outer}), each lane	SRS			-2.6	dBm
Conditions of stressed receiver sensitivity test					
Stressed eye closure for PAM4 (SECQ)			3.4		dB
OMA _{outer} of each aggressor lane			1.4		dBm

High Speed Electrical Specifications

Parameter	Min	Typical	Max	Units	Notes
Receiver electrical output characteristics at TP4					
Signaling rate per lane		26.5625		GBd	
AC common-mode output voltage(RMS)		-	17.5	mV	
Differential peak-to-peak output voltage			900	mV	
Near-end ESMW (Eye symmetry mask width)		0.265		UI	
Near-end Eye height, differential	70			mV	
Far-end ESMW (Eye symmetry mask width)		0.2		UI	
Far-end Eye height, differential	30			mV	
Far-end pre-cursor ISI ratio	-4.5		2.5	%	
Differential termination mismatch			10	%	
Transition time (min, 20% to 80%)	9.5			ps	
DC common mode voltage	-350		2850	mV	
Transmitter electrical input characteristics at TP1					
Signaling rate, per lane		26.5625		GBd	
Differential pk-pk input voltage tolerance	900			mV	
Differential termination mismatch			10	%	
Module stressed input test	Per Section 120E.3.4.1, IEEE802.3bs				
Single-ended voltage tolerance range	-0.4		3.3	V	
Common-mode voltage	-350		2850	mV	

Receiver Output Power Thresholds for Loss of Signal (LOS)

Parameter	Min	Typical	Max	Units
RX_LOS_Assert Min/Max	-15.0			dBm
RX_LOS_De-Assert Min/Max			-8.9	dBm
RX_LOS_Hysteresis		1.5		dB

Digital Diagnostic Monitoring Specifications

Parameter	Unit	Specification
Temperature Monitor absolute error	degC	± 3
Voltage Monitor absolute error	%	± 5

I _{bias} Monitor absolute error	%	± 10
Transmit Power (Tx) Monitor absolute error	dB	± 3.0
Received Power (Rx) Monitor absolute error	dB	± 3.0

QSFP-DD Edge Connector and Pinout Description

The electrical pinout of the QSFP-DD module is shown in Figure 2 below.

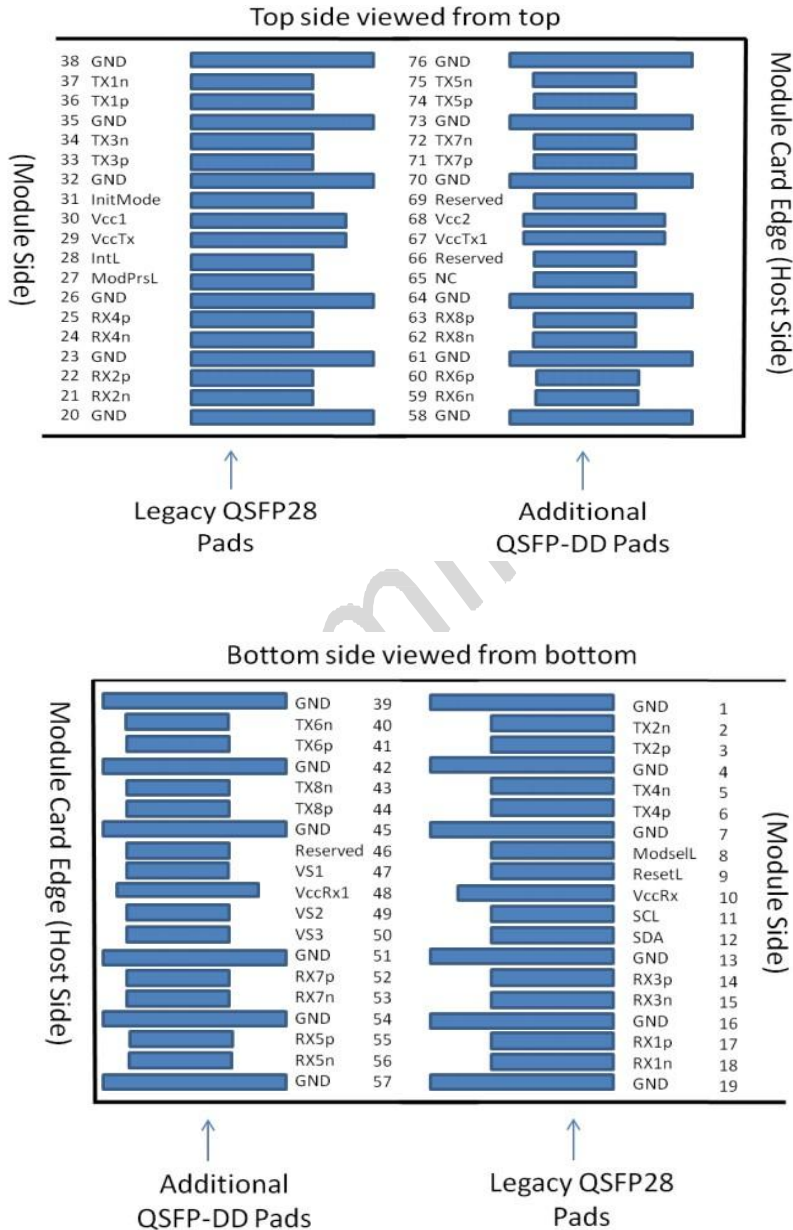

Figure 1. Host PCB QSFP-DD pad assignment top view

Pin No.	Symbol	Description	Note
1	GND	Ground	1
2	Tx2n	Transmitter Inverted Data Input	
3	Tx2p	Transmitter Non-Inverted Data output	
4	GND	Ground	1
5	Tx4n	Transmitter Inverted Data Input	
6	Tx4p	Transmitter Non-Inverted Data output	
7	GND	Ground	1
8	ModSelL	Module Select	
9	ResetL	Module Reset	
10	VccRx	3.3V Power Supply Receiver	2
11	SCL	2-Wire serial Interface Clock	
12	SDA	2-Wire serial Interface Data	
13	GND	Ground	1
14	Rx3p	Receiver Non-Inverted Data Output	
15	Rx3n	Receiver Inverted Data Output	
16	GND	Ground	1
17	Rx1p	Receiver Non-Inverted Data Output	
18	Rx1n	Receiver Inverted Data Output	
19	GND	Ground	1
20	GND	Ground	1
21	Rx2n	Receiver Inverted Data Output	
22	Rx2p	Receiver Non-Inverted Data Output	
23	GND	Ground	1
24	Rx4n	Receiver Inverted Data Output	
25	Rx4p	Receiver Non-Inverted Data Output	
26	GND	Ground	1
27	ModPrsL	Module Present	
28	IntL	Interrupt	
29	VccTx	3.3V power supply transmitter	2
30	Vcc1	3.3V power supply	2
31	Init Mode	Initialization mode	
32	GND	Ground	1
33	Tx3p	Transmitter Non-Inverted Data Input	
34	Tx3n	Transmitter Inverted Data Output	
35	GND	Ground	1
36	Tx1p	Transmitter Non-Inverted Data Input	
37	Tx1n	Transmitter Inverted Data Output	
38	GND	Ground	1

39	GND	Ground	1
40	Tx6n	Transmitter Inverted Data Input	
41	Tx6p	Transmitter Non-Inverted Data output	
42	GND	Ground	1
43	Tx8n	Transmitter Inverted Data Input	
44	Tx8p	Transmitter Non-Inverted Data output	
45	GND	Ground	1
46	Reserved	For Future Use	3
47	VS1	Module Vendor Specific 1	3
48	VccRx1	3.3V Power Supply	2
49	VS2	Module Vendor Specific 2	3
50	VS3	Module Vendor Specific 3	3
51	GND	Ground	1
52	Rx7p	Receiver Non-Inverted Data Output	
53	Rx7n	Receiver Inverted Data Output	
54	GND	Ground	1
55	Rx5p	Receiver Non-Inverted Data Output	
56	Rx5n	Receiver Inverted Data Output	
57	GND	Ground	1
58	GND	Ground	1
59	Rx6n	Receiver Inverted Data Output	
60	Rx6p	Receiver Non-Inverted Data Output	
61	GND	Ground	1
62	Rx8n	Receiver Inverted Data Output	
63	Rx8p	Receiver Non-Inverted Data Output	
64	GND	Ground	1
65	NC	No Connect	3
66	Reserved	For Future Use	3
67	VccTx1	3.3V power supply	2
68	Vcc2	3.3V power supply	2
69	Reserved	For Future Use	3
70	GND	Ground	1
71	Tx7p	Transmitter Non-Inverted Data Input	
72	Tx7n	Transmitter Inverted Data Output	
73	GND	Ground	1
74	Tx5p	Transmitter Non-Inverted Data Input	
75	Tx5n	Transmitter Inverted Data Output	
76	GND	Ground	1

Module Block Diagram

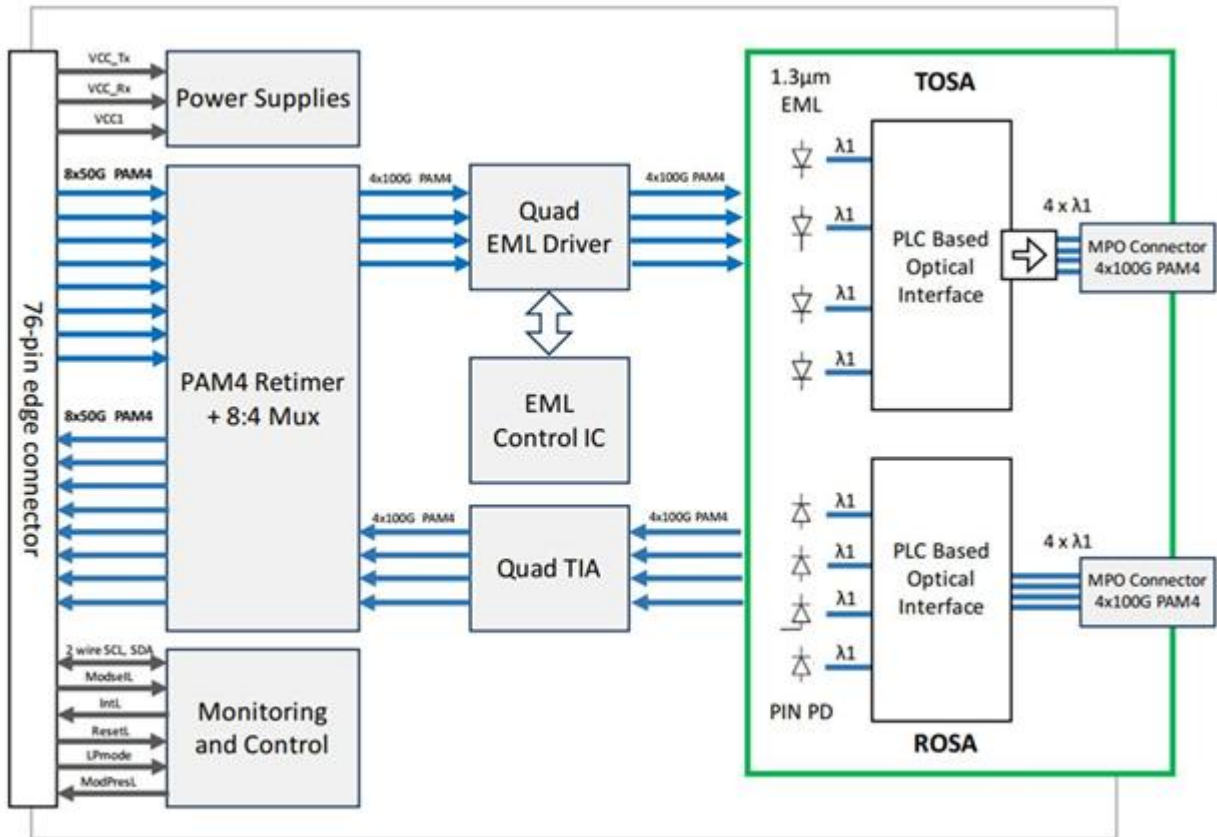
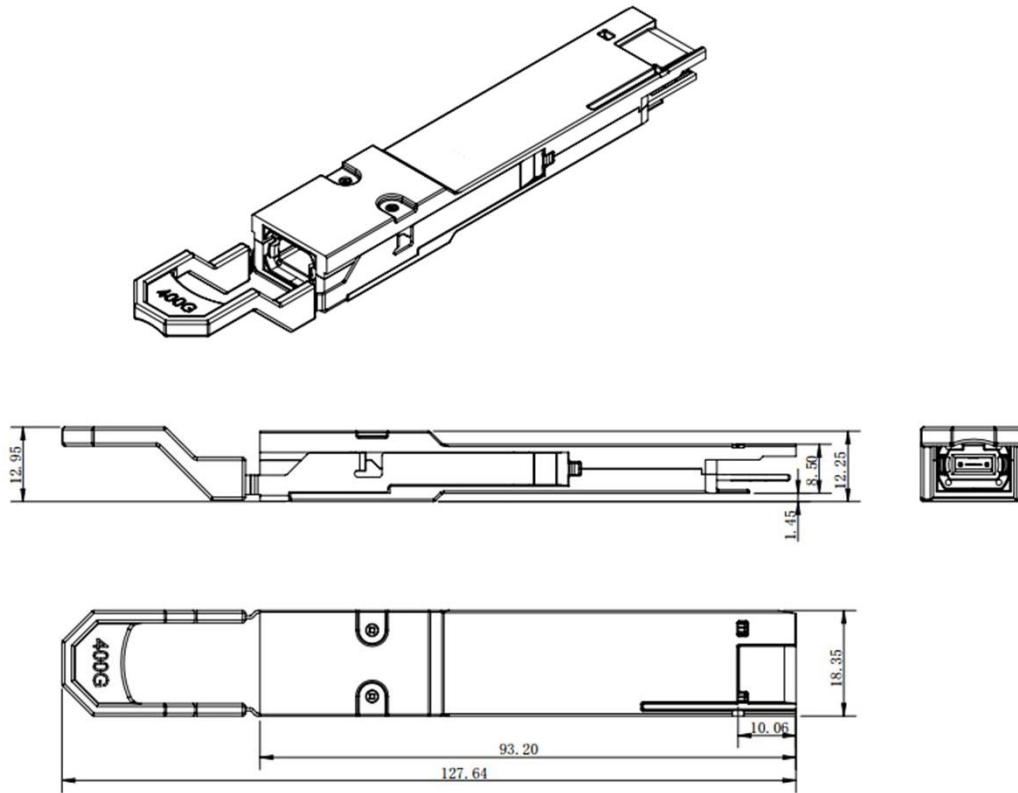

Figure 2. Module Block Diagram

Mechanical Specifications

Pull tab color: Blue

Panon:30



Ordering information

Part Number	Product Description
LQ4-CW400-DR4C	400Gbps, QSFP56-DD, DR4, 500m, 0° C~+70° C, with DDM