

## LS-MM8525-S1I

SFP28 25Gb/s 850nm 100m DDMI

### Product Features

- Up to 25.7813Gbps Data Links
- 850nm VCSEL laser transmitter and PIN receiver
- Maximum link length of 70m on OM3
- Multimode Fiber (MMF) and 100m on OM4 MMF
- Hot-pluggable SFP28 footprint
- Duplex LC receptacles
- Low power dissipation
- RoHS compliant and lead-free
- Support Digital Diagnostic Monitor interface
- Single +3.3V power supply
- 0°C to +70°C case operating temperature

### Applications

- 25GBASE-SR Ethernet

### Compliance

- SFF-8472
- SFF-8402
- SFF-8432
- SFF-8431



## Ordering Information

Part No.	Bit Rate (Gbps)	Laser (nm)	Distance	Fiber Type	DDMI	Connector	Temp
LS-MM8525-S1C	25.78125	850	70M OM3/100M OM4	MMF	YES	LC	0°C~+70°C

## Pin Diagram

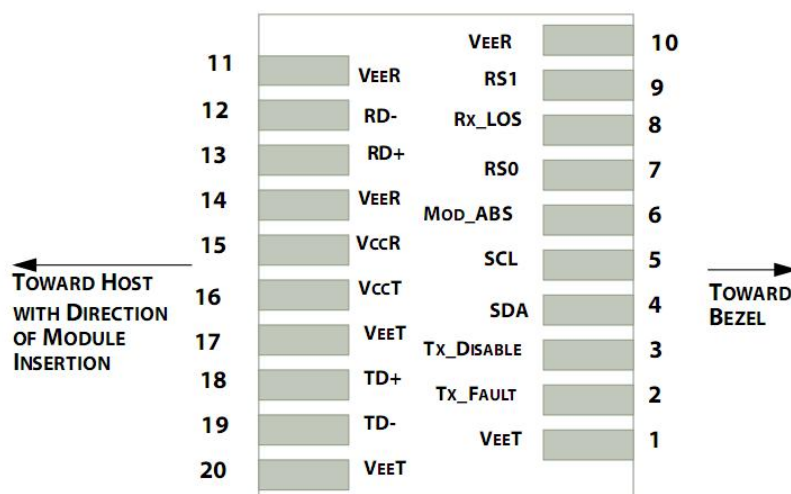

Pinout of Connector Block on Host Board

## Pin Descriptions

Pin	Symbol	Name/Description	NOTE
1	VEET	Module transmitter ground	1
2	Fault	Module transmitter Fault	2
3	Disable	Transmitter Disable; Turns off transmitter laser output	3
4	SDL	2 wire serial interface data input/output (SDA)	4
5	SCL	2 wire serial interface clock input (SCL)	4
6	MOD-ABS	Module Absent, connect to VeeR or VeeT in the module	2

7	RS0	Rate select0: module inputs and are pulled low to VeeT with >30 kΩ resistors in the module.	
8	LOS	Receiver Loss of Signal Indication	
9	RS1	Rate select1: module inputs and are pulled low to VeeT with >30 kΩ resistors in the module.	
10	VeeR	Module receiver ground	1
11	VeeR	Module receiver ground	1
12	RD-	Receiver inverted data out put	
13	RD+	Receiver non-inverted data out put	
14	VeeR	Module receiver ground	1
15	VccR	Module receiver 3.3V supply	
16	VccT	Module transmitter 3.3V supply	
17	VeeT	Module transmitter ground	1
18	TD+	Transmitter non-inverted data out put	
19	TD-	Transmitter inverted data out put	
20	VeeT	Module transmitter ground	1

**Notes:**

1. The module ground pins shall be isolated from the module case.
2. This pin is an open collector/drain output pin and shall be pulled up with 4.7K-10Kohms to Host\_Vcc on the host board.
3. This pin shall be pulled up with 4.7K-10Kohms to VccT in the module.
4. This pin is an open collector/drain output pin and shall be pulled up with 4.7K-10Kohms to Host\_Vcc on the host board.

## Absolute Maximum Ratings

Parameter	Symbol	Min	Type	Max	Unit	Ref.
Maximum Supply Voltage	Vcc	-0.5		3.6	V	
Storage Temperature	TS	-40		85	°C	1
Case Operating Temperature	TOP	0		70	°C	
Relative Humidity	RH	0		85	%	2

## Notes:

- 1.Limited by the fiber cable jacket, not the active ends.
- 2.Non-condensing.

**Optical Characteristics (TOP = 0°C to 70°C, VCC = 3.3 ± 5% Volts)**

Parameter	Symbol	Min.	Typ.	Max.	Unit	Remark
<b>Transmitter</b>						
Center Wavelength	$\lambda_c$	840	850	860	nm	
RMS Spectral Width	Pm			0.6	nm	
Average Output Power	Pavg	-8.4		2.4	dBm	
Optical Modulation Amplitude (OMA)	Poma	-6.4		3	dBm	
Extinction Ratio	ER	2			dB	
Transmitter Dispersion Penalty	TDEC			4.3	dB	
Optical Return Loss Tolerance	TOL			12	dB	
Transmitter OFF Output Power	POff			-30	dBm	
Transmitter eye mask definition {X1, X2, X3, Y1, Y2, Y3}, Hit ratio 1.5E-3		{0.3, 0.38, 0.45, 0.35, 0.41, 0.5}				
<b>Receiver</b>						
Center Wavelength	$\lambda_c$	840	850	860	nm	
Receiver Stress Sensitivity, OMA				-5.2	dBm	
Receiver Sensitivity, Average Power				-10.3	dBm	
Receiver Reflectance	Rfl			-26	dBm	
Loss of Signal Assert	P <sub>A</sub>	-30			dBm	
Loss of Signal De-assert	P <sub>D</sub>			-13	dBm	
LOS Hysteresis	P <sub>D</sub> - P <sub>A</sub>	0.5			dB	

**Electrical Characteristics (TOP = 0°C to 70°C, VCC = 3.3 ± 5% Volts)**

Parameter	Symbol	Min	Type	Max	Unit	Ref.
Supply Voltage	Vcc	3.135	3.3	3.465	V	
Supply Current	Icc			300	mA	

Transmitter						
Input differential impedance	R <sub>in</sub>		100			1
Differential data input swing	V <sub>in</sub> , pp	200		1000	mV	
Transmit Disable Voltage	V <sub>D</sub>	2		V <sub>CC</sub>	V	
Transmit Enable Voltage	V <sub>EN</sub>	V <sub>ee</sub>		V <sub>ee</sub> +0.8	V	
Receiver						
Differential data output swing	V <sub>out</sub> , pp	200		1000	mV	2
LOS Fault	V <sub>LOS_fault</sub>	2		V <sub>CC</sub>	V	3
LOS Normal	V <sub>LOS_norm</sub>	V <sub>ee</sub>		V <sub>ee</sub> +0.8	V	3
Power Supply Noise Tolerance	V <sub>CC</sub> T/V <sub>CC</sub> R	Per SFF-8431 Rev 4.1			mVpp	

Notes:

1. Connected directly to TX data input pins.AC coupling from pins into laser driver IC.
2. Into 100Ω differential termination.
3. Measured with Module Compliance Test Board and OMA test pattern. Use of four 1's and four 0's in sequence in the PRBS<sup>9</sup> is an acceptable alternative. SFF-8431 Rev 4.1

## Digital Diagnostic Memory Map

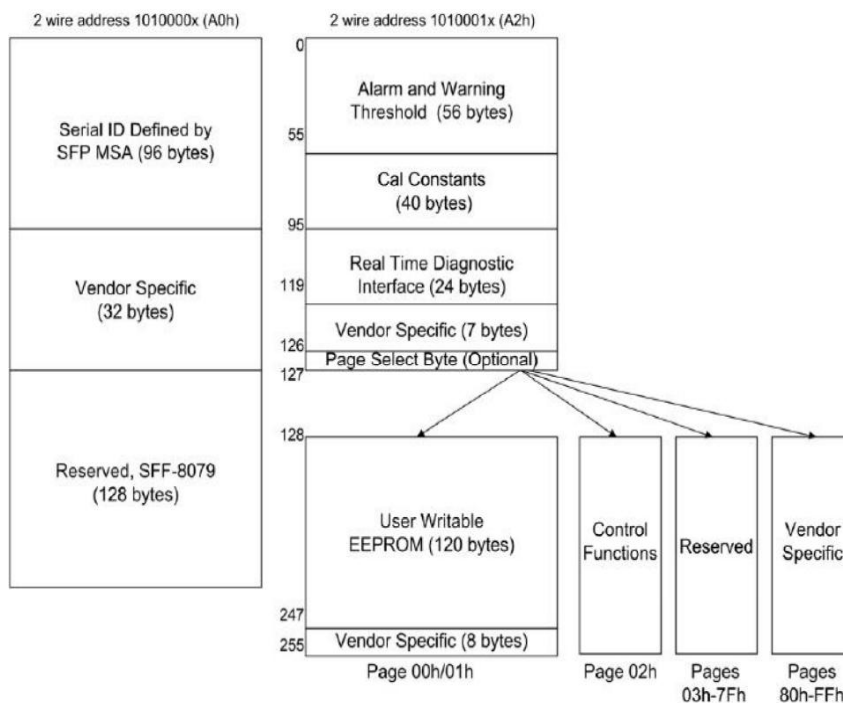

## Digital Diagnostic Monitoring Information

Parameter	Unit	Accuracy
Case Temperature	°C	±3
Supply Voltage	V	±3%
Tx Bias Current	mA	±10%
Tx Optical Power	dB	±3
Rx Optical Power	dB	±3

## Recommended Interface Circui

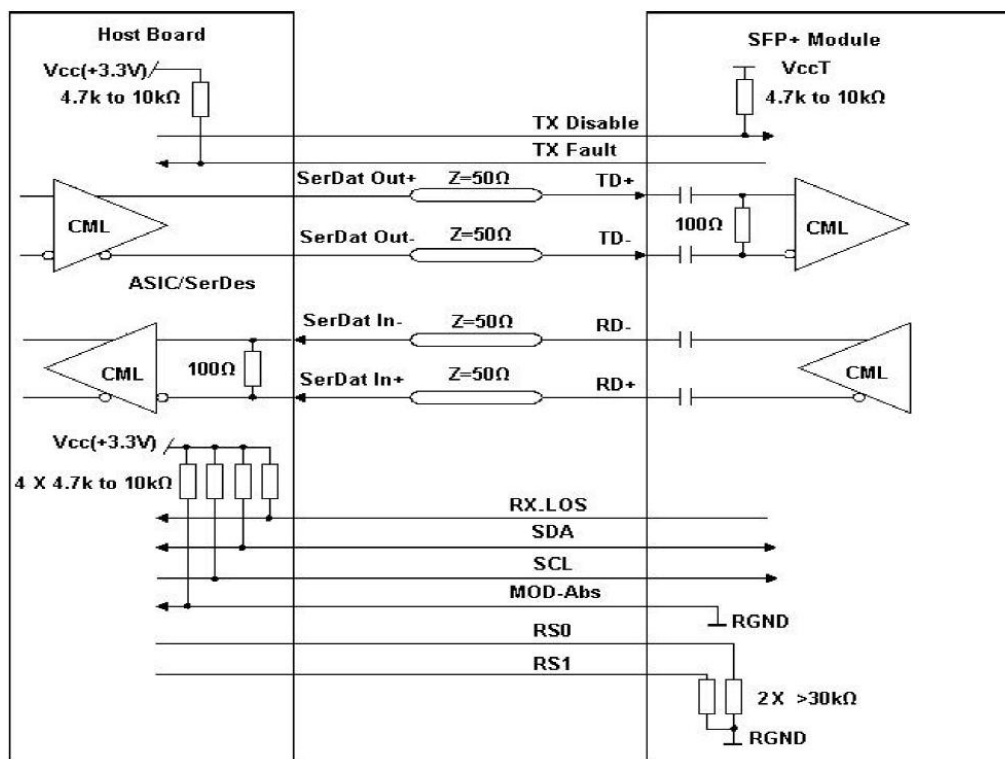

## Mechanical Dimensions

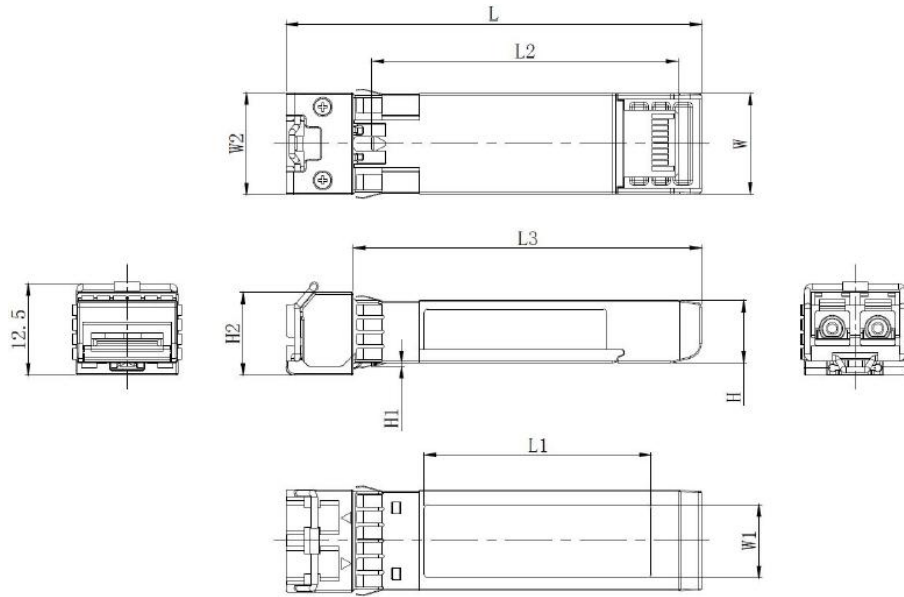

Unit: mm

	L	L1	L2	L3	W	W1	W2	H	H1	H2
MAX	56.9	31.2	41.95	47.7	13.8	10.2	14.0	8.6	0.6	11.5
Typical	56.7	31.0	41.80	47.5	13.7	10.0	-	8.5	0.5	11.3
MIN	56.5	30.8	41.65	47.3	13.5	9.8	-	8.4	0.4	11.1