

LS-SM3125E-10E

10G/25Gbps SFP28 1310nm Duplex 10km Transceiver

Product Feature

- Up to 10G/25.78 Gb/s bi-directional data links
- Hot-pluggable SFP28 footprint
- Up to 10 km on 9/125µm SMF
- Built-in digital diagnostic functions
- 1310nm DFB laser transmitter
- Duplex LC connector
- Metal enclosure, for lower EMI
- RoHS compliant
- 1.2W maximum power consumption with established link
- Supports optical and electrical loopback functions
- Single 3.3V power supply
- Case operating temperature
 - Commercial: 0°C to +70°C
 - Extended: -20°C to +85°C
 - Industrial: -40°C to +85°C

Applications

- 25GBASE-LR
- eCPRI
- Data center



Product Description

SFP28 transceivers are designed for use in Ethernet links up to 10G/25.78 Gb/s data rate and up to 10 km link length. They are compliant SFF-8472 Rev 12.2b and IEEE 802.3cc, and compatible with SFF-8432a and applicable portions of SFF- 8431 Rev. 3.0c. The product is RoHS compliant and lead-free per Directive 2011/96/EUd.

Product Selection

Part Number	Operating Case temperature	DDMI
LS-SM3125E-10C	Commercial(0~70°C)	Yes
LS-SM3125E-10E	Extended(-20°C~85°C)	Yes
LS-SM3125E-10I	Industrial(-40~85°C)	Yes

Pin Descriptions

Pin	Symbol	Name/Description	NOTE
1	VEET	Module transmitter ground	1
2	Fault	Module transmitter Fault	2
3	Disable	Transmitter Disable; Turns off transmitter laser output	3
4	SDL	2 wire serial interface data input/output (SDA)	4
5	SCL	2 wire serial interface clock input (SCL)	4
6	MOD-ABS	Module Absent, connect to VeeR or VeeT in the module	2
7	RS0	Rate select0: module inputs and are pulled low to VeeT with >30 kΩ resistors in the module.	
8	LOS	Receiver Loss of Signal Indication	
9	RS1	Rate select1: module inputs and are pulled low to VeeT with >30 kΩ resistors in the module.	
10	VeeR	Module receiver ground	1
11	VeeR	Module receiver ground	1
12	RD-	Receiver inverted data out put	
13	RD+	Receiver non-inverted data out put	
14	VeeR	Module receiver ground	1
15	VccR	Module receiver 3.3V supply	
16	VccT	Module transmitter 3.3V supply	
17	VeeT	Module transmitter ground	1
18	TD+	Transmitter non-inverted data out put	

19	TD-	Transmitter inverted data out put	
20	VeET	Module transmitter ground	1

Notes:

1. The module ground pins shall be isolated from the module case.
2. This pin is an open collector/drain output pin and shall be pulled up with 4.7K-10Kohms to Host_Vcc on the host board.
3. This pin shall be pulled up with 4.7K-10Kohms to VccT in the module.
4. This pin is an open collector/drain output pin and shall be pulled up with 4.7K-10Kohms to Host_Vcc on the host board.

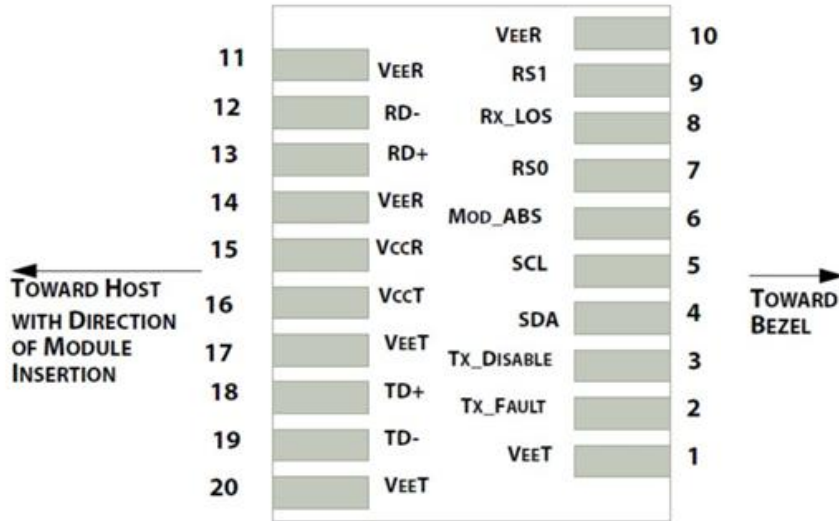

Pin-out of Connector Block on Host Board

Absolute Maximum Ratings

Parameter	Symbol	Min.	Typ.	Max.	Unit	Note
Storage Temperature	Ts	-50		+95	°C	
Relative Humidity	RH	0		95	%	
Power Supply Voltage	VCC	-0.5		+4	V	

Recommended Operating Conditions

Parameter	Symbol	Min.	Typ.	Max.	Unit	Note
Case Operating Temperature	T _A	0		70	°C	Commercial
		-20		85	°C	Extended
		-40		85	°C	Industrial
Power Supply Voltage	VCC	3.13	3.3	3.47	V	
Power Supply Current	ICC			300	mA	Commercial
				430	mA	Extended
				430	mA	Industrial
Data Rate1	BR	24.3	25.78	26.5	Gbps	
Data Rate2	BR	9.953	10	10.31	Gbps	
9/125um G.652 SMF	Lmax			10	km	

Electrical Characteristics

Parameter	Symbol	Min.	Typ.	Max.	Unit	Note
Transmitter						
Tx Disable Input-High	VDISH	2		V _{CC} +0.3	V	
Tx Disable Input-High	VDISH	2		V _{CC} +0.3	V	
Tx Disable Input-Low	VDISL	0		0.8	V	
Tx Fault Input-High	VTxFH	2		V _{CC} +0.3	V	
Tx Fault Input-Low	VTxFL	0		0.8	V	
Receiver						
LOSS -High	VLOSH	2		V _{CC} +0.3	V	
LOSS -Low	VLOSL	0		0.8	V	

Optical Characteristics

Parameter	Symbol	Min.	Typ.	Max.	Unit	Note
Transmitter						
Average Output Power (24.33Gb/s – 25.78Gb/s)	POUT	-7		2	dBm	1, 2
Average Output Power (9.95Gb/s – 10.31Gb/s)	POUT	-8.2		0.5	dBm	1, 2
Extinction Ratio	ER	3.5			dB	
Center Wavelength	λ_c	1290	1310	1330	nm	DFB Laser
Spectral Width (RMS)@25Gb/s	$\Delta\lambda$			0.6	nm	
Side Mode Suppression Ratio	SMSR	30			dB	
Spectrum Bandwidth(-20dB)	σ			1	nm	3
Transmitter OFF Output Power	Poff			-45	dBm	
Receiver						
Receiver Sensitivity (24.33Gb/s – 25.78Gb/s)	SENS			-13	dBm	4
Receiver Sensitivity (9.95Gb/s – 10.31Gb/s)	SENS			-14.4	dBm	4
Receiver Overload		2			dBm	3
Input Optical Wavelength	λ_c	1260		1610	nm	PIN-TIA
LOS De-assert	LOSD			-15	dBm	
LOS Assert	LOSA	-30			dBm	2
LOS Hysteresis		0.5		6	dB	

Note:

- Class 1 Laser Safety per FDA/CDRH and EN (IEC) 60825 regulations.
- High Bandwidth Mode. Class 1 Laser Safety per FDA/CDRH and EN (IEC) 60825 regulations.
- For information only.
- Test at 25.78Gb/s, PRBS 2³¹-1, BER 5x10⁻⁵
Test at 10.31Gb/s, PRBS 2³¹-1, BER 10⁻¹²

EEPROM Information

EEPROM memory map specific data field description is as below:

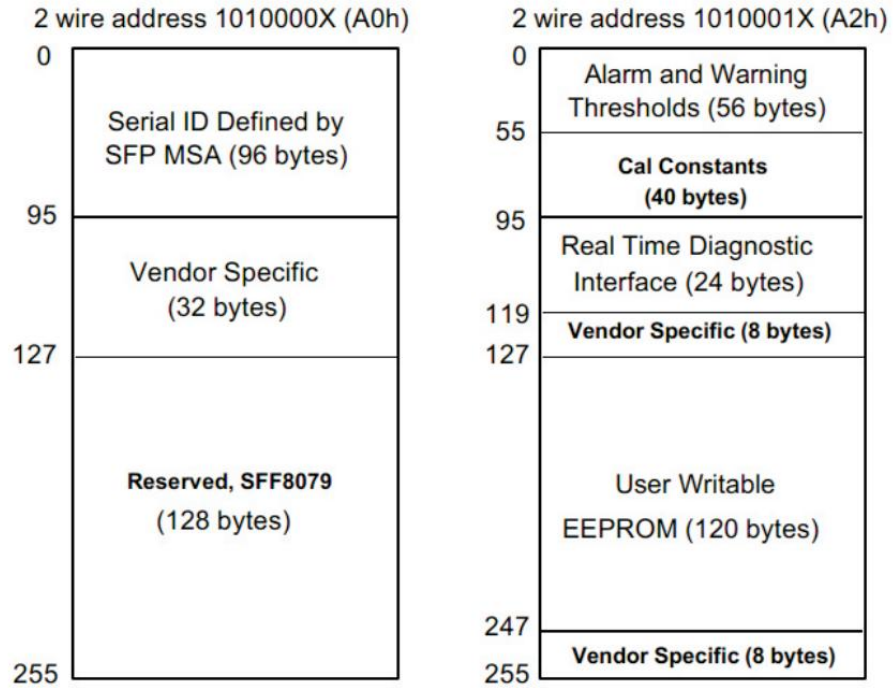

Digital Diagnostic Monitoring Interface

Five transceiver parameter values are monitored. The following table defines the monitored parameter's accuracy.

Parameter	Range	Accuracy	Calibration
Temperature	0 to +70°C (C)	±3°C	Internal
	-40 to +85°C (I)		
Voltage	3.13 to 3.47V	±3%	Internal
Bias Current	0 to 100mA	±10%	Internal
TX Power	-8 to +3dBm	±3dBm	Internal
RX Power	-14 to +3dBm	±3dBm	Internal

Recommend Circuit Schematic

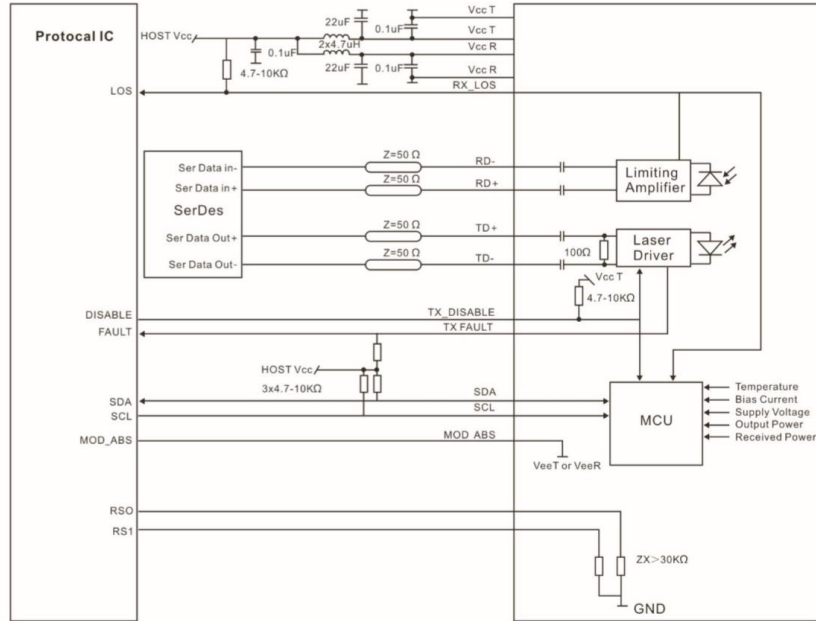

Mechanical Specifications

